

EYE BOLTS

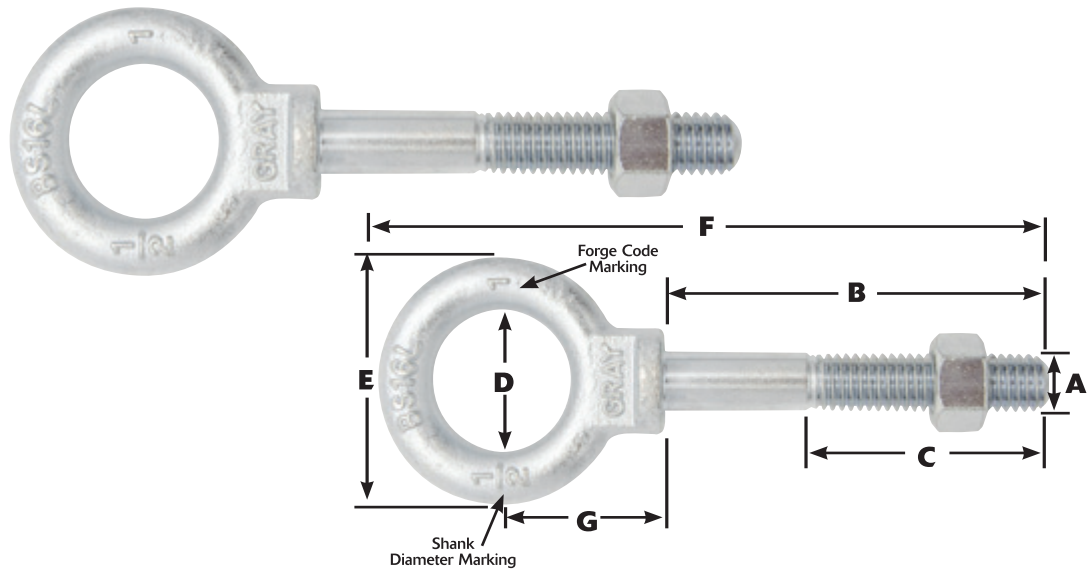

Shoulder Pattern Long Shanks

Part No.	Thread Size UNC-2A A	Shank Length B	Thread Length C	I.D. Eye D	O.D. Eye E	Overall Length F	Center of Eye to Shdr. G	Approx. Weight per Piece lbs.	Working Load Limit lbs.
BS08L	1/4-20	2	1.5	3/4	1 3/16	3 3/8	3/4	0.07	650
BS08XL	1/4-20	4	2.0	3/4	1 3/16	5 3/8	3/4	0.10	650
BS10L	5/16-18	2.25	1.5	7/8	1 7/16	3 13/16	15/16	0.13	1,200
BS10XL	5/16-18	4.25	2.5	7/8	1 7/16	5 13/16	15/16	0.17	1,200
BS12L	3/8-16	2.50	1.5	1	1 11/16	4 21/32	1 1/8	0.22	1,550
BS12XL	3/8-16	4.50	2.0	1	1 11/16	6 1/32	1 1/8	0.28	1,550
BS16L	1/2-13	3.25	2.0	1 3/16	2 1/8	5 23/32	1 3/8	0.53	2,600
BS16XL	1/2-13	6	3.0	1 3/16	2 1/8	8 15/32	1 3/8	0.67	2,600
BS20L	5/8-11	4	3.0	1 3/8	2 9/16	7	1 21/32	0.96	5,200
BS20XL	5/8-11	6	3.0	1 3/8	2 9/16	9	1 21/32	1.14	5,200
BS24L	3/4-10	4.50	3.0	1 1/2	2 13/16	7 3/4	1 13/16	1.45	7,200
BS24XL	3/4-10	6	3.0	1 1/2	2 13/16	9 1/4	1 13/16	1.63	7,200

Dimensions in Inches

Note: Rated capacity is for 0° vertical pulls. Never apply loads greater than Rated Capacity to any eye bolt. Proof tested in accordance with ASTM A489 and Federal Spec. ANSI B18.15. Traceability and Mechanical test values are available with each shipment upon request.

FEATURES

- Forged.
- Carbon Steel.
- Zinc Plated.
- Includes Assembled Galvanized Hex Nut.

WARNING

RATED CAPACITY LIMIT IS DRASTICALLY REDUCED WHEN LOADING AT ANY ANGLE. LOADS MAY SLIP OR FALL CAUSING SERIOUS INJURY OR DAMAGE IF PROPER INSTALLATION AND LIFTING PROCEDURES ARE NOT FOLLOWED.

Direction of Pull	Rated Capacity
15 degrees	80% of working load limit
30 degrees	65% of working load limit
45 degrees	30% of working load limit
46+ degrees	Not recommended

ALWAYS USE A SHOULDER EYE BOLT WHEN PERFORMING ANGULAR LIFTS.